



Township of Evesham

"Respecting Diversity, Preserving Dignity"

Mayor Jaclyn Veasy - Councilwoman Heather Cooper - Councilwoman Ginamarie Espinoza - Councilman Eddie Freeman, III - Councilwoman Patricia Hansen

984 Tuckerton Road • Marlton • NJ 08053 • 856-983-2900 • www.evesham-nj.org



CMP Policy and Implementation Committee Meeting 9:30 a.m Friday, February 23, 2024

1. Township of Evesham request for a potential Memorandum of Agreement (MOA) with the Pinelands Commission for the Municipal Park known as the Black Run Preserve (BRP).

2. BRP Municipal Park:
 - a. 700+ acre Municipal Park located in the southern section of the Township. As the entire park is listed on the municipal Recreation Open Space Inventory (ROSI) it is also subject to NJDEP Green Acres requirements in addition to Pinelands Commission regulations.

General Notes & Data Sources:
 This Geographic Information System (GIS) Recreation and Open Space Inventory (ROSI) Map is for demonstration purposes only, any use of this product with respect to accuracy and precision shall be the sole responsibility of the end user.
 The areas shown on this ROSI map are referenced, in part, from ground surveys, aerial surveys and recorded plans, and documents, and are to be used for approximate location purposes only.
 Water bodies: NJDEP NHD Dataset, 2002.
 NJDOT Roads: NJGN, 2017.
 Additional cadastral GIS mapping data, such as, waterways, roadways, etc. was obtained from the New Jersey Geographic Information Network (NJGIN), the New Jersey Department of Transportation (NJDOT), the New Jersey Department of Environmental Protection (NJDEP), the New Jersey Office of Information Technology (NJGIT), and the New Jersey Office of GIS (NJOGIS). The data was obtained and provided by the various New Jersey Departments at the New Jersey Geographic Information Network (NJGIN) <https://njgis-newjersey.opendata.arcgis.com>. This secondary product has not been verified by (NJGIN/NJGIT/NJOGIS/NJDOT/NJDEP) and is not state-authorized.
 All positions are based on the following:
 • NAD 83 (horizontal datum)
 • New Jersey State Plane Coordinate System
 • English units (feet)
 The geodetic accuracy and precision of the Geographic Information System (GIS) data contained in this mapping has not been developed nor verified by a professional licensed land surveyor and shall not be nor is intended to be used in matters requiring delineation and location of true ground horizontal and/or vertical controls.

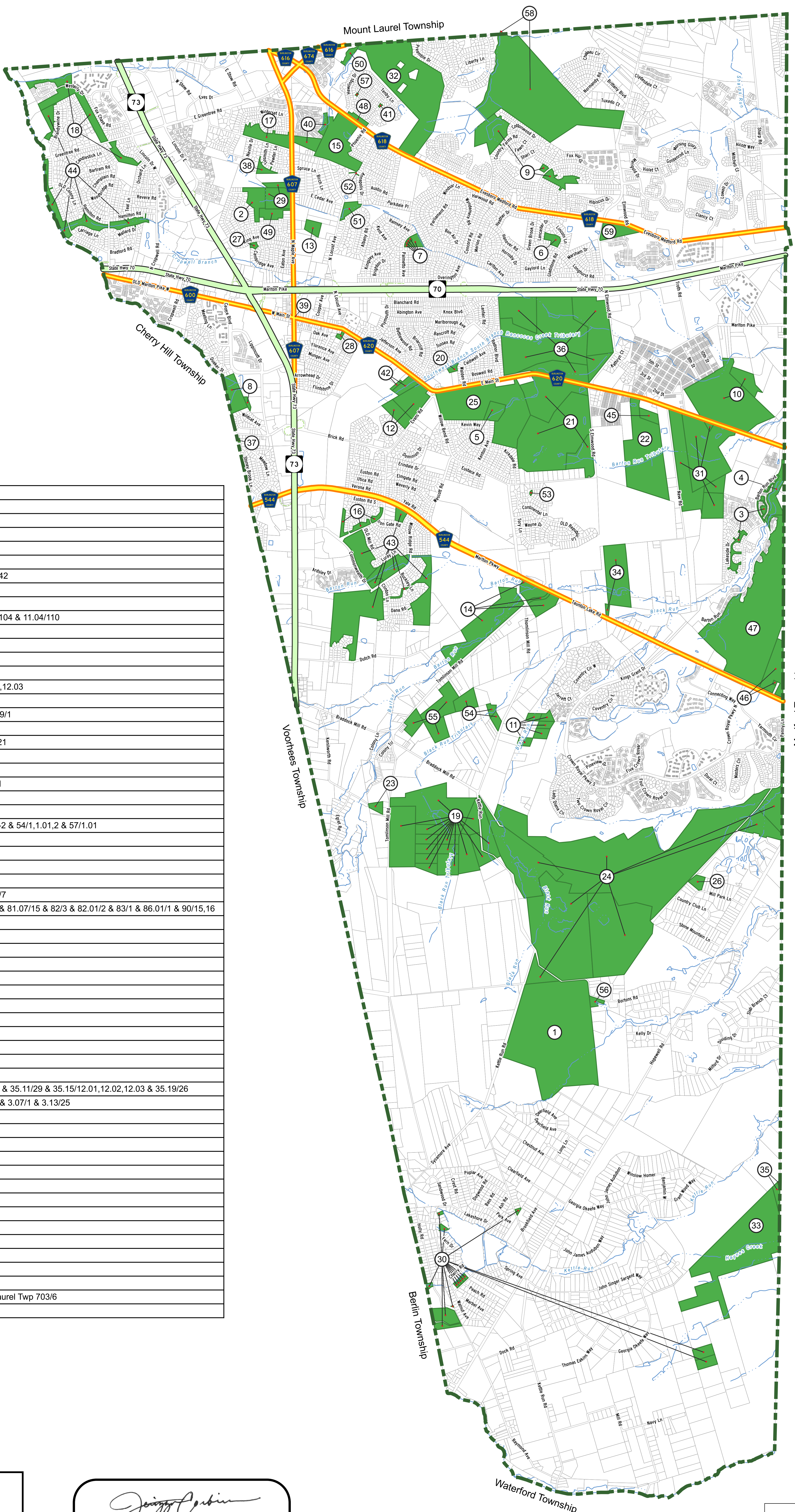
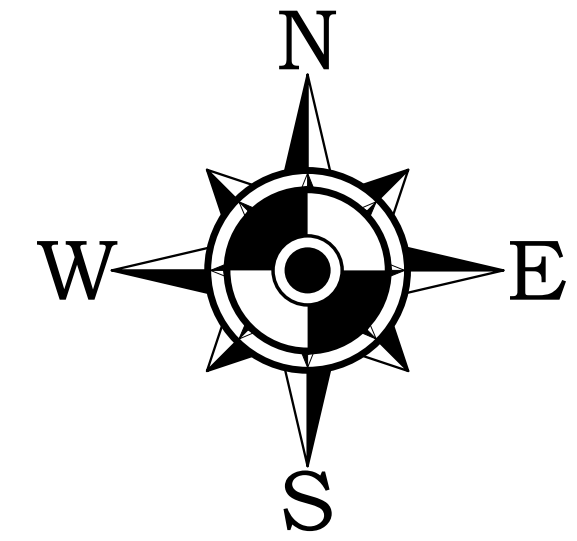

Map Key	Park Name	Block/Lot
1	Aerohaven	57/1
2	Baker Tract	20.15/6
3	Barton Run	44.17/1 & 44.19/57
4	Barton Run Lake	44.23/2.04
6	Heathrow Park	13.23/33
7	Cambridge Park	13.06/22,23,24,25,42
5	Brush Hollow	29/2
8	Carrefour	24.24/2.02,101
9	Country Farms	11.01/174 & 11.02/104 & 11.04/110
10	Croft Farm	31/8.07,9
11	Density Transfer	41/19,20,21,23,26
12	Downs Tract	26/10-11
13	Eisenhower Park	10/3.06
14	Evans Tract	40/2 & 41/12,12.01,12.03
15	Evesboro Downs	9/9.02
16	Glen Eayre	33.07/28,29 & 33.09/1
17	Greenlane Farms	7.04/41
18	Greentree Village	1.08/34,76 & 3.30/21
19	Hamilton Georgetown Road	47/2 & 48/4-16
20	Heritage	28.16/10
21	Indian Springs	29/3,3.01 & 29.12/1
22	Johnston Tract	30/2
23	Kenilworth	49/5
24	Kings Grant II	47/1 & 52/1 & 53/1-2 & 54/1,1.01,2 & 57/1.01
25	Koppenhaver Tract	29/1
26	Little Mill	54.04/22
27	London Square Park	20.11/25
28	Kain Memorial Park	4.11/5
29	Marlgreen Tract	6.17/11.01 & 20.15/7
30	Marlon Lakes	81.04/18-22,56,60 & 81.07/15 & 82/3 & 82.01/2 & 83/1 & 86.01/1 & 90/15,16
31	Memorial Park	44/5-8,11.01
32	Musulin	11/1
33	Pachoango	90/11
34	Project Heal Camp	38/6,16.01
35	Rancocas Watershed	90/9,9.01
36	Savich Tract	28.20/6-10
37	Tara	34.07/7
38	The Maples	6.15/1
39	Town Clock	4.05/17.05
40	Vineyards	9.01/124,190
41	Westbury Chase Park	8.06/18
42	Wiley Tract	26/8-9
43	Willow Ridge	35.03/4 & 35.09/31 & 35.11/29 & 35.15/12.01,12.02,12.03 & 35.19/26
44	Woodstream	1.01/2 & 3.01/1,44 & 3.07/1 & 3.13/25
45	Morrison Parcel	30/2.04
46	Barton Road	44.31/2-3
47	Vacant Land	44.26/110
48	Open Space	8.07/26
49	Open Space	20.07/1
50	Church Rd Farm	8.18/5
51	Park	13.64/13
52	Open Space	13.64/53
53	Vacant Land	38.02/1
54	Density Transfer	42/16,18,23
55	Density Transfer	46/1,3,4
56	Open Space	57/3.04
57	Tot Lot	8.02/30
58	Park (Formerly Beagle Club)	11.52/2 & Mount Laurel Twp 703/6
59	Open Space	18/3

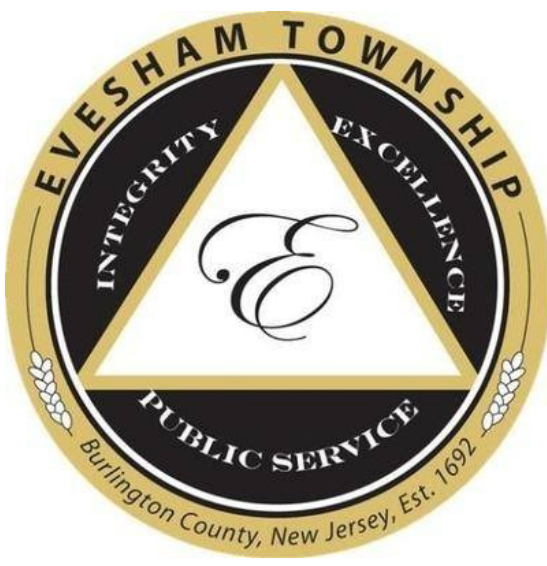

Recreational and Open Space
Evesham Township
 Burlington County New Jersey
 September 17th, 2021 Scale 1:1500
REMINGTON & VERNICK ENGINEERS
 2059 SPRINGDALE ROAD, CHERRY HILL, NJ 08003
 (856) 795-9595, FAX (856) 795-1882, RVE.COM
 Certificate of Authorization: 24 02 2800390
 Excellence • Innovation • Service

Jenizza Corbin
 DATE: 12/15/2022
JENIZZA CORBIN, PP
 NJ PROFESSIONAL PLANNER NO. 33L100681200

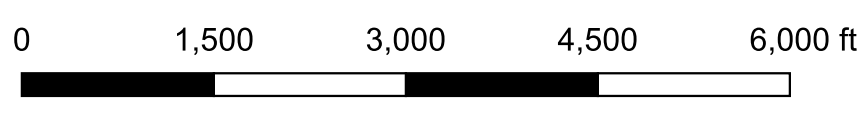

Legend

- Open Space/Park (Green fill)
- Parcel (Thin grey outline)
- Stream (Blue line)
- Waterbody (Blue area)
- Municipal Boundary (Dashed green line)
- State Highway (Thick orange line)
- County Road (Thin orange line)
- Ramp (Dashed orange line)

REVISIONS

NO.	DESCRIPTION	DATE	BY	CHK
1	Added Former Beagle Club & 387 Evesboro-Medford Road	Dec 7 th , 2022	ES	KZ
2				
3				
4				

REVISIONS				
NO.	DESCRIPTION	DATE	BY	CHK BY
1	TRAIL MAP	8/22/22	KT	
2	FORMATTING	9/21/22	LP	
3	FORMATTING	9/27/22	LP	
4	FORMATTING	12/7/2023	ES	
5	FORMATTING	1/4/2024	ES	

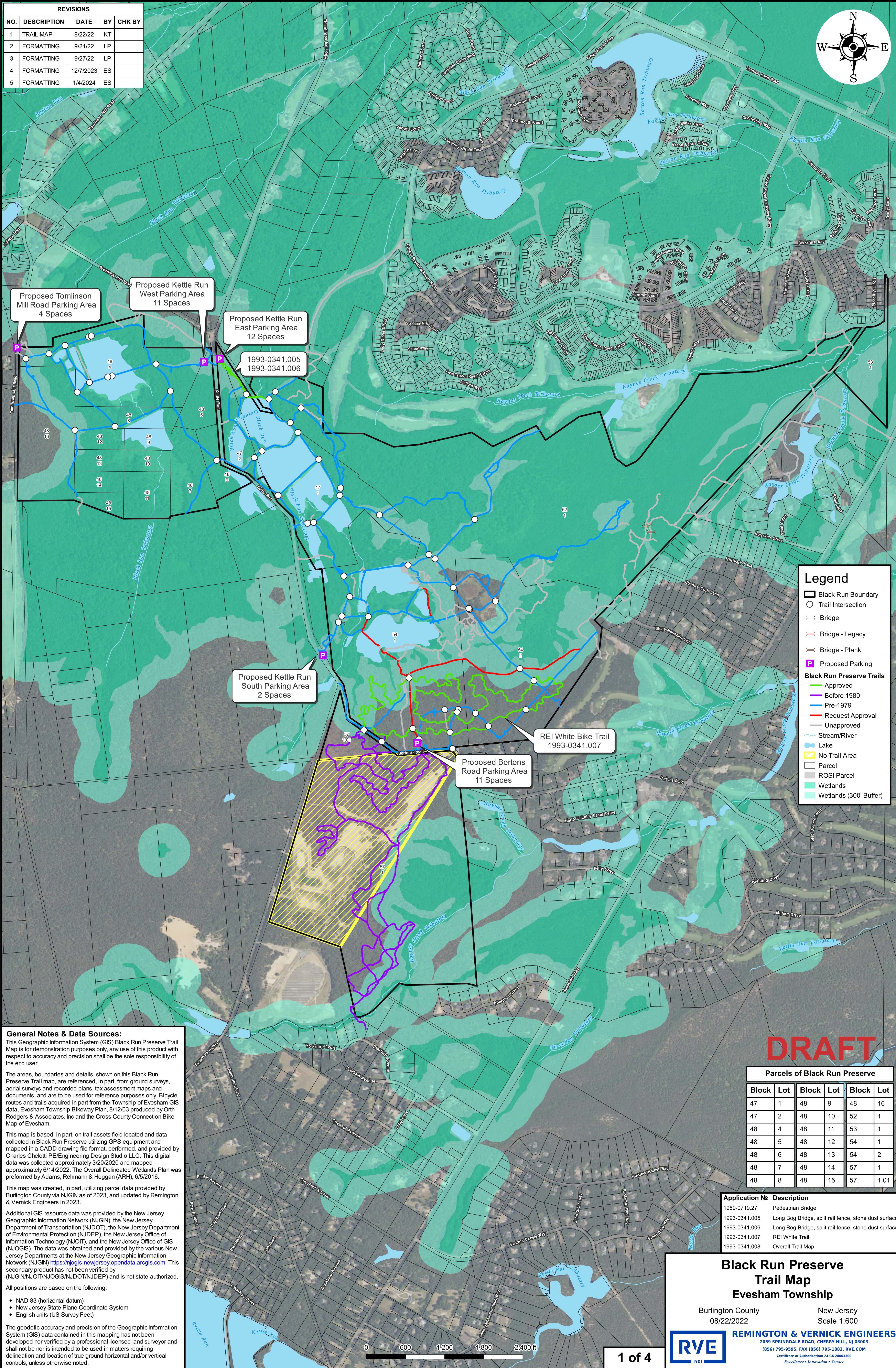
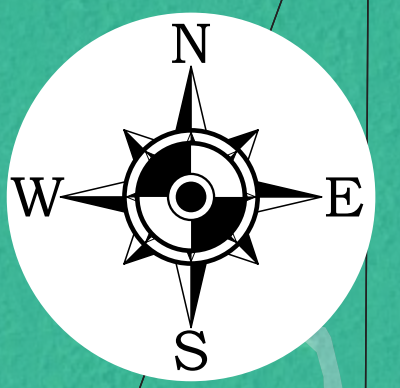

Proposed Tomlinson Mill Road Parking Area
4 Spaces

Proposed Kettle Run West Parking Area
11 Spaces

Proposed Kettle Run East Parking Area
12 Spaces

1993-0341.005
1993-0341.006

Proposed Kettle Run South Parking Area
2 Spaces

Proposed Bortons Road Parking Area
11 Spaces

REI White Bike Trail
1993-0341.007

Legend	
	Black Run Boundary
	Trail Intersection
	Bridge
	Bridge - Legacy
	Bridge - Plank
	Proposed Parking
Black Run Preserve Trails	
	Approved
	Before 1980
	Pre-1979
	Request Approval
	Unapproved
	Stream/River
	Lake
	No Trail Area
	Parcel
	ROSI Parcel
	Wetlands
	Wetlands (300' Buffer)

General Notes & Data Sources:
This Geographic Information System (GIS) Black Run Preserve Trail Map is for demonstration purposes only, any use of this product with respect to accuracy and precision shall be the sole responsibility of the end user.

The areas, boundaries and details, shown on this Black Run Preserve Trail map, are referenced, in part, from ground surveys, aerial surveys and recorded plans, tax assessment maps and documents, and are to be used for reference purposes only. Bicycle routes and trails acquired in part from the Township of Evesham GIS data, Evesham Township Bikeway Plan, 8/12/03 produced by Orth-Rodgers & Associates, Inc and the Cross County Connection Bike Map of Evesham.

This map is based, in part, on trail assets field located and data collected in Black Run Preserve utilizing GPS equipment and mapped in a CADD drawing file format, performed, and provided by Charles Chelotti PE/Engineering Design Studio LLC. This digital data was collected approximately 3/20/2020 and mapped approximately 6/14/2022. The Overall Delineated Wetlands Plan was performed by Adams, Rehmann & Heggan (ARH), 6/5/2016.

This map was created, in part, utilizing parcel data provided by Burlington County via NJGN as of 2023, and updated by Remington & Vernick Engineers in 2023.

Additional GIS resource data was provided by the New Jersey Geographic Information Network (NJGIN), the New Jersey Department of Transportation (NJDOT), the New Jersey Department of Environmental Protection (NJDEP), the New Jersey Office of Information Technology (NJGIT), and the New Jersey Office of GIS (NJOGIS). The data was obtained and provided by the various New Jersey Departments at the New Jersey Geographic Information Network (NJGIN) <https://njgis-newjersey.opendata.arcgis.com>. This secondary product has not been verified by (NJGIN/NJOT/NJOGIS/NJDOT/NJDEP) and is not state-authorized.

All positions are based on the following:

- NAD 83 (horizontal datum)
- New Jersey State Plane Coordinate System
- English units (US Survey Feet)

The geodetic accuracy and precision of the Geographic Information System (GIS) data contained in this mapping has not been developed nor verified by a professional licensed land surveyor and shall not be nor is intended to be used in matters requiring delineation and location of true ground horizontal and/or vertical controls, unless otherwise noted.

DRAFT

Parcels of Black Run Preserve					
Block	Lot	Block	Lot	Block	Lot
47	1	48	9	48	16
47	2	48	10	52	1
48	4	48	11	53	1
48	5	48	12	54	1
48	6	48	13	54	2
48	7	48	14	57	1
48	8	48	15	57	1.01

Application No	Description
1989-0719.27	Pedestrian Bridge
1993-0341.005	Long Bog Bridge, split rail fence, stone dust surface
1993-0341.006	Long Bog Bridge, split rail fence, stone dust surface
1993-0341.007	REI White Trail
1993-0341.008	Overall Trail Map

Black Run Preserve Trail Map
Evesham Township
Burlington County New Jersey
08/22/2022 Scale 1:600

REMINGTON & VERNICK ENGINEERS
2059 SPRINGDALE ROAD, CHERRY HILL, NJ 08003
(856) 795-9595, FAX (856) 795-1882, RVE.COM
Certificate of Authorization: 24 GA 28003300
Excellence • Innovation • Service

REVISIONS				
No	DESCRIPTION	DATE	BY	CHK BY
1	Added wetlands with buffer, fixed trail alignment and distance	2/5/2024	ES	
2	Added additional proposed features	2/15/2024	ES	
3				
4				

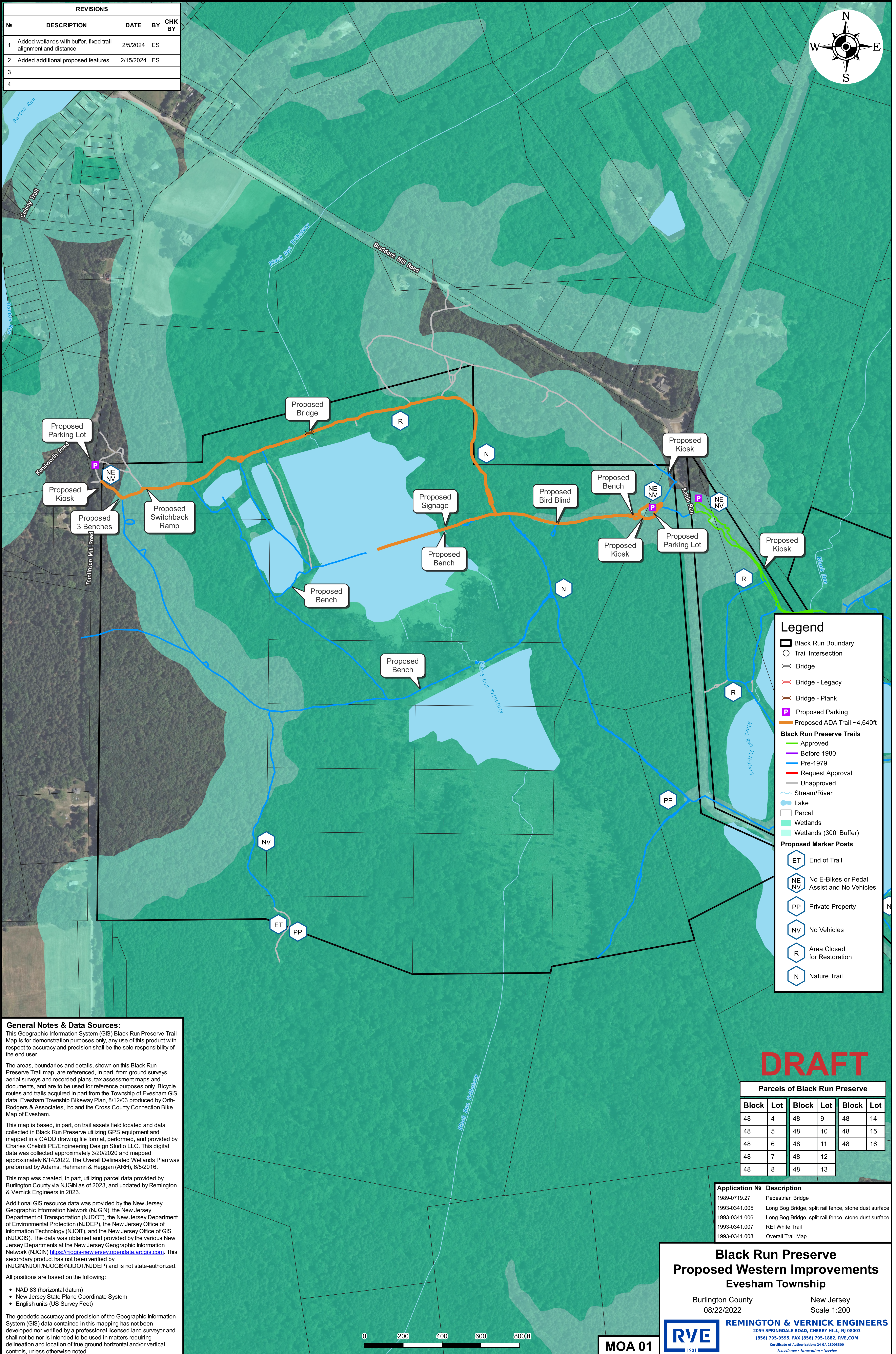
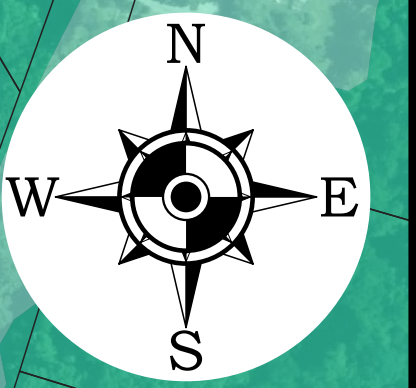

Legend

- Black Run Boundary
- Trail Intersection
- Bridge
- Bridge - Legacy
- Bridge - Plank
- Proposed Parking
- Proposed ADA Trail ~4,640ft
- Black Run Preserve Trails**
 - Approved
 - Before 1980
 - Pre-1979
 - Request Approval
 - Unapproved
- Stream/River
- Lake
- Parcel
- Wetlands
- Wetlands (300' Buffer)
- Proposed Marker Posts**
 - ET End of Trail
 - NE NV No E-Bikes or Pedal Assist and No Vehicles
 - PP Private Property
 - NV No Vehicles
 - R Area Closed for Restoration
 - N Nature Trail

General Notes & Data Sources:
 This Geographic Information System (GIS) Black Run Preserve Trail Map is for demonstration purposes only, any use of this product with respect to accuracy and precision shall be the sole responsibility of the end user.

The areas, boundaries and details, shown on this Black Run Preserve Trail map, are referenced, in part, from ground surveys, aerial surveys and recorded plans, tax assessment maps and documents, and are to be used for reference purposes only. Bicycle routes and trails acquired in part from the Township of Evesham GIS data, Evesham Township Bikeway Plan, 8/12/03 produced by Orth-Rodgers & Associates, Inc and the Cross County Connection Bike Map of Evesham.

This map is based, in part, on trail assets field located and data collected in Black Run Preserve utilizing GPS equipment and mapped in a CADD drawing file format, performed, and provided by Charles Chelotti PE/Engineering Design Studio LLC. This digital data was collected approximately 3/20/2020 and mapped approximately 6/14/2022. The Overall Delineated Wetlands Plan was performed by Adams, Rehmann & Heggan (ARH), 6/5/2016.

This map was created, in part, utilizing parcel data provided by Burlington County via NJGN as of 2023, and updated by Remington & Verrick Engineers in 2023.

Additional GIS resource data was provided by the New Jersey Geographic Information Network (NJGN), the New Jersey Department of Transportation (NJDOT), the New Jersey Department of Environmental Protection (NJDEP), the New Jersey Office of Information Technology (NJOT), and the New Jersey Office of GIS (NJOGIS). The data was obtained and provided by the various New Jersey Departments at the New Jersey Geographic Information Network (NJGN) <https://njgis-newjersey.opendata.arcgis.com>. This secondary product has not been verified by (NJGIN/NJOT/NJOGIS/NJDOT/NJDEP) and is not state-authorized.

All positions are based on the following:

- NAD 83 (horizontal datum)
- New Jersey State Plane Coordinate System
- English units (US Survey Feet)

The geodetic accuracy and precision of the Geographic Information System (GIS) data contained in this mapping has not been developed nor verified by a professional licensed land surveyor and shall not be nor is intended to be used in matters requiring delineation and location of true ground horizontal and/or vertical controls, unless otherwise noted.

DRAFT

Parcels of Black Run Preserve

Block	Lot	Block	Lot	Block	Lot
48	4	48	9	48	14
48	5	48	10	48	15
48	6	48	11	48	16
48	7	48	12		
48	8	48	13		

Application No Description

1989-0719.27	Pedestrian Bridge
1993-0341.005	Long Bog Bridge, split rail fence, stone dust surface
1993-0341.006	Long Bog Bridge, split rail fence, stone dust surface
1993-0341.007	REI White Trail
1993-0341.008	Overall Trail Map

**Black Run Preserve
 Proposed Western Improvements
 Evesham Township**

Burlington County New Jersey
 08/22/2022 Scale 1:200

REMINGTON & VERRICK ENGINEERS
 2059 SPRINGDALE ROAD, CHERRY HILL, NJ 08003
 (856) 795-9595, FAX (856) 795-1882, RVE.COM
 Certificate of Authorization: 24 GA 28003300
 Excellence • Innovation • Service

MOA 01

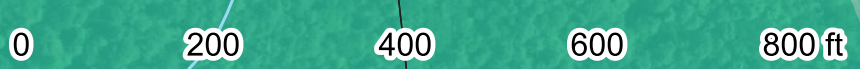

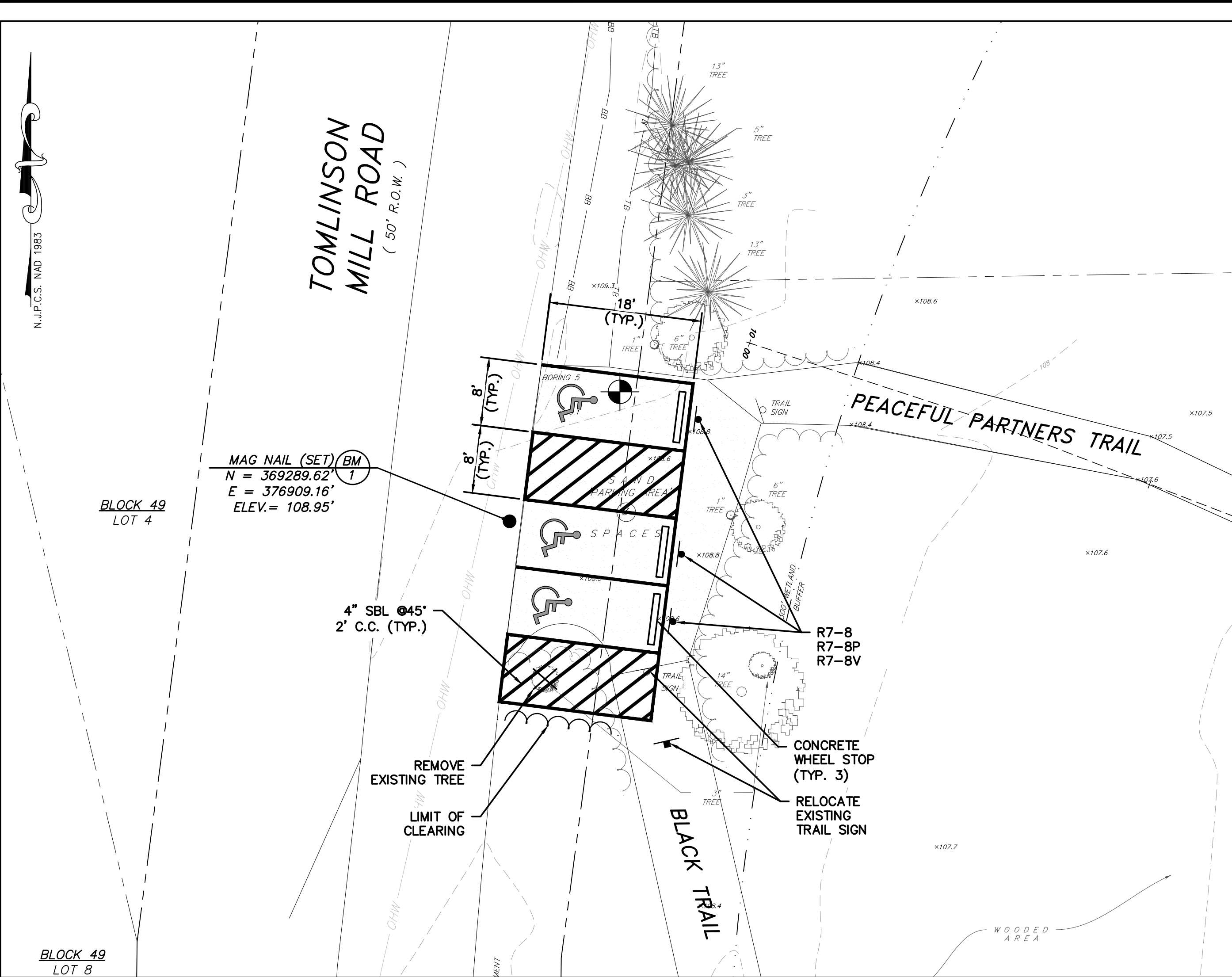

PLAN
SCALE: 1"=10'

GRAPHIC SCALE
(IN FEET)
1 inch = 20 ft.

GENERAL NOTES

- CONTRACTOR SHALL VERIFY ALL DIMENSIONS AND EXISTING CONDITIONS IN THE FIELD PRIOR TO THE START OF THE CONSTRUCTION, ANY ERRORS OR DISCREPANCIES SHALL BE BROUGHT TO THE ATTENTION OF THE ENGINEER IMMEDIATELY.
- LOCATION OF EXISTING UTILITIES ARE APPROXIMATE AND MUST BE VERIFIED IN THE FIELD PRIOR TO THE START OF CONSTRUCTION.
- THE CONTRACTOR SHALL USE EXCAVATED MATERIALS FOR BACKFILL UNLESS OTHERWISE DIRECTED BY THE ENGINEER.
- ALL PAVED AND CONCRETE AREAS DISTRIBUTED DURING CONSTRUCTION SHALL BE RESTORED TO EXISTING CONDITION AT LEAST EQUAL TO THAT WHICH EXISTED PRIOR TO THE START OF CONSTRUCTION.
- ALL GRASSED OR WOODED AREAS DISTRIBUTED DURING CONSTRUCTION SHALL BE TOPSOILED AND SEEDED.
- ALL FILL SHALL BE PLACED IN 12" LAYERS AND THOROUGHLY COMPACTED TO THE SATISFACTION OF THE ENGINEER. IF BORROW FILL IS REQUIRED, IT SHALL BE SUBJECT TO THE APPROVAL OF THE ENGINEER.
- THE CONTRACTOR SHALL BE RESPONSIBLE FOR THE LOCATION AND PRESERVATION OF THE UNDERGROUND AND SURFACE UTILITIES AND STRUCTURES AT OR ADJACENT TO THE SITE OF CONSTRUCTION AND IT SHALL BE AT HIS OWN EXPENSE TO REPAIR OR REPLACE ANYTHING THAT HE DAMAGES.
- ALL CONSTRUCTION DETAILS NOT SHOWN SHALL BE IN ACCORDANCE WITH N.J.D.O.T. STANDARDS AS DETAILED IN:
 - "STANDARD ROADWAY CONSTRUCTION/TRAFFIC CONTROL/BRIDGE CONSTRUCTION DETAILS, 2016."
 - "ELECTRICAL BUREAU STANDARD DETAILS: 2007,"
 INCLUDING ALL APPLICABLE BASELINE DOCUMENT CHANGES AND APPENDICES. THESE DETAILS MAY BE PURCHASED THROUGH THE N.J.D.O.T. PLANS AND SPECIFICATION CENTER AT:
 1035 PARKWAY AVENUE,
 TRENTON, NEW JERSEY
 08625-0600
 (TELEPHONE: 1-609-530-2098)
- SEPARATE PAYMENT WILL NOT BE MADE FOR SAW CUTTING OF ANY KIND, BUT THE COST SHALL BE INCLUDED IN THE VARIOUS ITEMS OF THE PROPOSAL.
- PAYMENT FOR JOINT MATERIAL FOR ALL CONCRETE WORK WILL NOT BE MEASURED BUT SHALL BE INCLUDED IN THE VARIOUS ITEMS OF THE PROPOSAL.
- TRAFFIC CONTROL SHALL BE IN ACCORDANCE WITH THE LATEST DETAILS TCD-1 THROUGH TCD-5.
- THE CONTRACTOR SHALL BE RESPONSIBLE FOR ALL UTILITY MARK OUTS AND COMPLIANCE WITH ALL FEDERAL, STATE AND LOCAL CODES AND REGULATIONS.
- THE CONTRACTOR IS RESPONSIBLE FOR OBTAINING ALL NECESSARY PERMITS FOR CONSTRUCTION FROM THE APPROPRIATE GOVERNMENT AGENCIES, WHERE APPLICABLE.
- THE CONTRACTOR SHALL ADJUST THE POSITION OF ANY AND ALL PROPOSED STRUCTURES AND PLANTINGS TO ACCOMMODATE EXISTING UTILITIES AND BUILDING FEATURES. THE LANDSCAPE ARCHITECT SHALL BE CONTACTED WITH ANY QUESTIONS AND/OR CONCERNS.
- THE CONTRACTOR SHALL COORDINATE BENCH TYPE, PURCHASE AND INSTALLATION WITH OWNER.
- THE CONTRACTOR IS RESPONSIBLE FOR THE REMOVAL OF ALL DEBRIS AND EXCESS MATERIALS FROM THE JOB SITE.

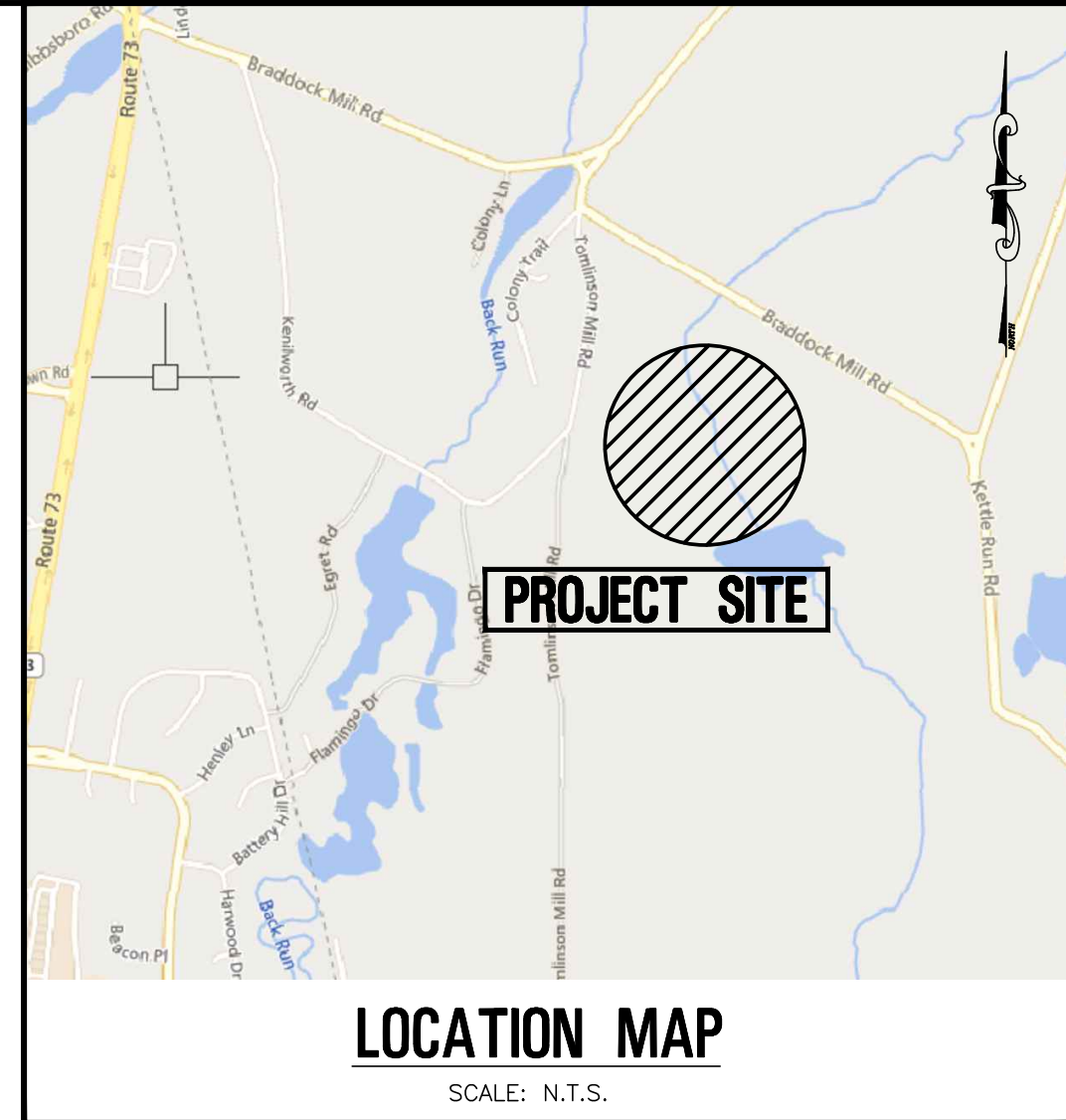

RVE
1901

REMINGTON & VERNICK ENGINEERS
2059 SPRINGDALE ROAD
CHERRY HILL, NJ 08003
(856) 795-9595, FAX (856) 795-1882
WEB ADDRESS : RVE.COM
Certification of Authorization: 24 GA 28003300
Excellence • Innovation • Service

DATE: _____
TIMOTHY R. STASZEWSKI
NJ PROFESSIONAL ENGINEER LIC. NO. 47542

PLANS WHICH DO NOT BEAR AN EMBOSSED SEAL ARE NOT VALID.

ALL DOCUMENTS PREPARED BY REMINGTON & VERNICK ENGINEERS AND AFFILIATES ARE INSTRUMENTS OF SERVICE IN RESPECT OF THE PROJECT. THEY ARE NOT INTENDED OR REPRESENTED TO BE SUITABLE FOR REUSE BY OWNER OR OTHERS ON EXTENSIONS OF THE PROJECT OR ON ANY OTHER PROJECT. ANY REUSE WITHOUT WRITTEN VERIFICATION OR ADAPTATION BY REMINGTON & VERNICK ENGINEERS AND AFFILIATES FOR THE SPECIFIC PURPOSE INTENDED WILL BE AT OWNERS SOLE RISK AND WITHOUT LIABILITY OR LEGAL EXPOSURE TO REMINGTON & VERNICK ENGINEERS AND AFFILIATES, AND OWNER SHALL INDEMNIFY AND HOLD HARMLESS REMINGTON & VERNICK ENGINEERS AND AFFILIATES FROM ALL CLAIMS, DAMAGES, LOSSES AND EXPENSES ARISING OUT OF OR RESULTING THEREFROM.

SURVEY NOTES & REFERENCES:

- THE HORIZONTAL DATUM IS BASED ON THE NEW JERSEY STATE PLANE COORDINATE SYSTEM (NAD-1983) AND THE VERTICAL DATUM IS BASED ON NAVD-1988 - 2012A ADJ. (ADD 1.17 FEET TO THESE ELEVATIONS TO CONVERT TO NGVD-1929 DATUM)
- PROPERTY AND RIGHT-OF-WAY LINES SHOWN ON THESE PLANS ARE APPROXIMATE LOCATIONS BASED ON THE CURRENT TAX MAPS OF THE TOWNSHIP OF CHERRY HILL, CAMDEN COUNTY, NEW JERSEY. PROPERTY AND RIGHT-OF-WAY LINES ARE SHOWN FOR GRAPHICAL INFORMATION ONLY AND HAVE NOT BEEN FIELD VERIFIED.
- EXISTING TOPOGRAPHIC CONDITIONS WERE SURVEYED BY REMINGTON & VERNICK ENGINEERS UNDER THE SUPERVISION OF CHARLES E. ADAMSON, N.J.P.L.S. LICENSE NO. 42627. THE SURVEY WORK WAS COMPLETED ON AUGUST 24 & SEPTEMBER 12, 2023. ADDITIONAL TOPOGRAPHIC SURVEY COMPLETED JANUARY 11, 2024.
- WETLAND DELINEATION & LOCATION PERFORMED BY REMINGTON & VERNICK ENGINEERS ON AUGUST 15, 2023.
- THIS PLAN AND SURVEY DOES NOT CERTIFY TO THE LOCATION, BOTH HORIZONTAL AND VERTICAL, OF ANY UNDERGROUND UTILITY OR STRUCTURE THAT WAS NOT EXPOSED FOR DIRECT MEASUREMENT.

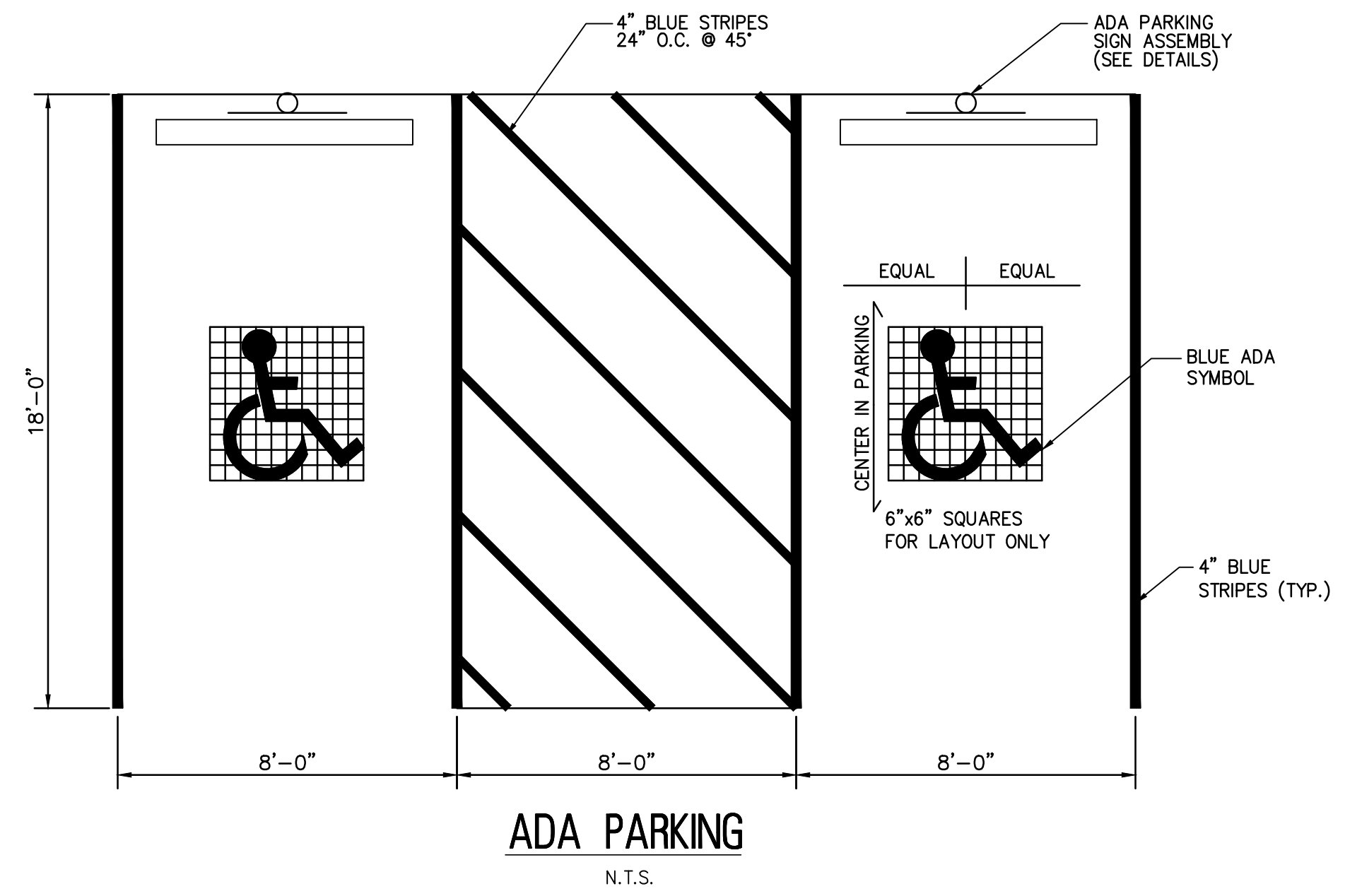
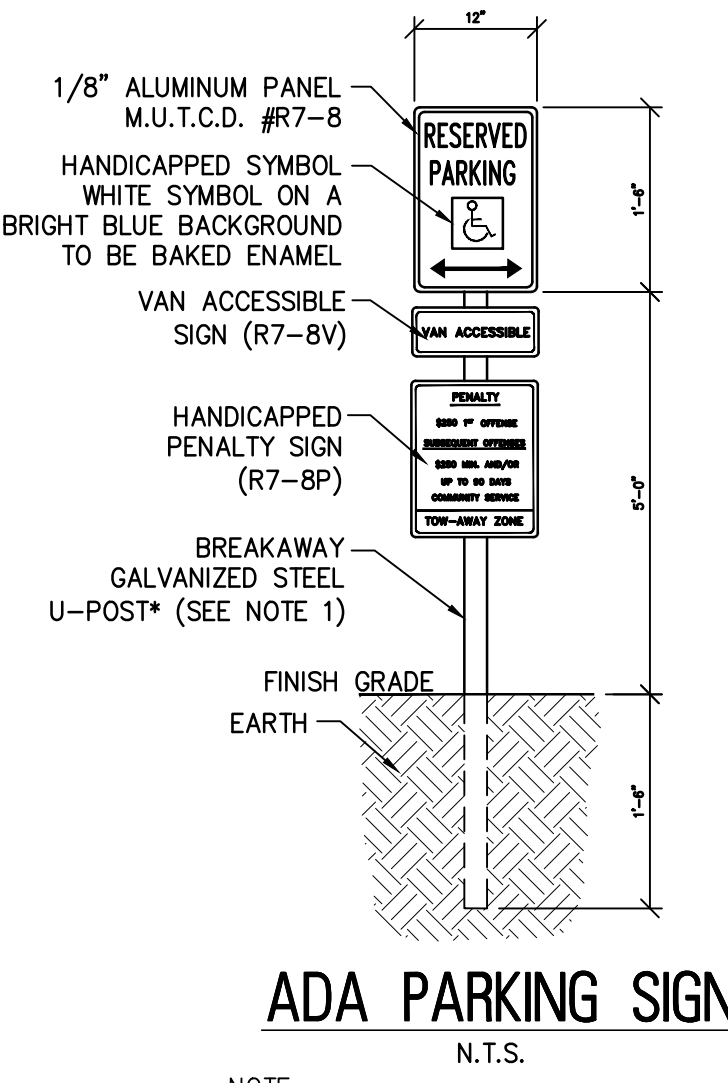
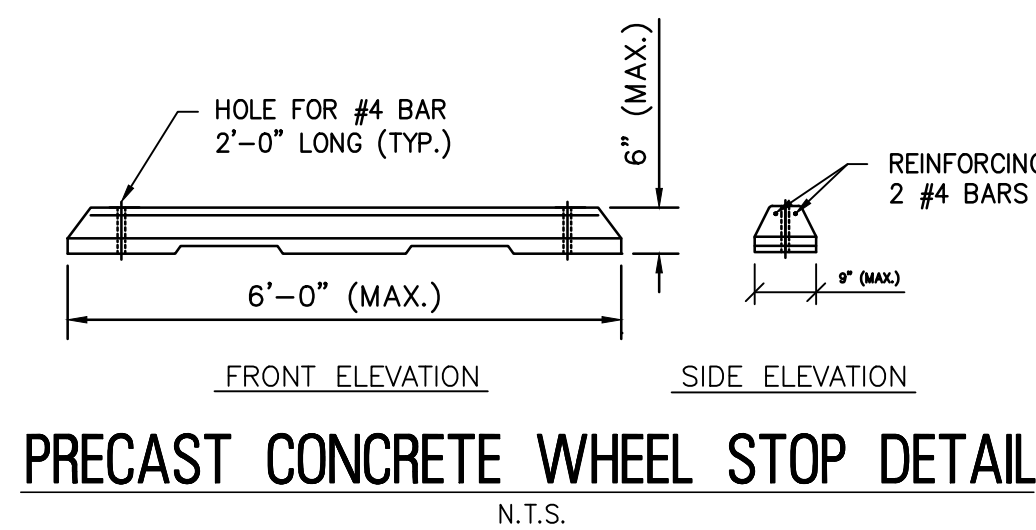
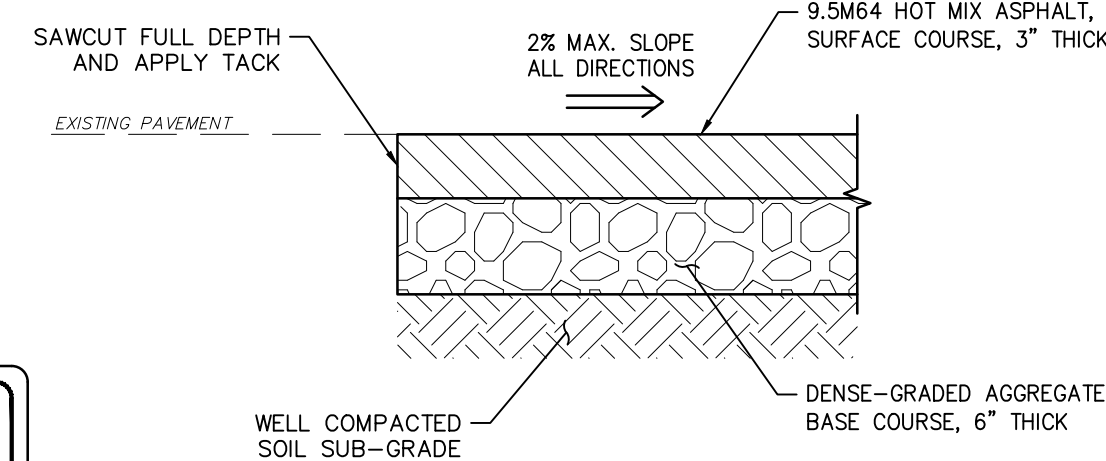

NO.	REVISION	DATE	BY	CHK

CONSTRUCTION PLAN

BLACK RUN RESERVE
TOMLINSON MILL ROAD TRAIL IMPROVEMENTS
EVESHAM BOROUGH BURLINGTON COUNTY NEW JERSEY

DRAWN BY:	DESIGN BY:	CHECKED BY:	SCALE:
J.J.M.	T.R.S.	T.R.S.	AS NOTED
DATE:	01/20/24		
JOB No.:	03131246		
1 of 1			

REVISIONS				
NO.	DESCRIPTION	DATE	BY	CHK BY
1	TRAIL MAP	8/22/22	KT	
2	FORMATTING	9/21/22	LP	
3	FORMATTING	9/27/22	LP	
4	FORMATTING	12/7/2023	ES	
5	FORMATTING	1/4/2024	ES	

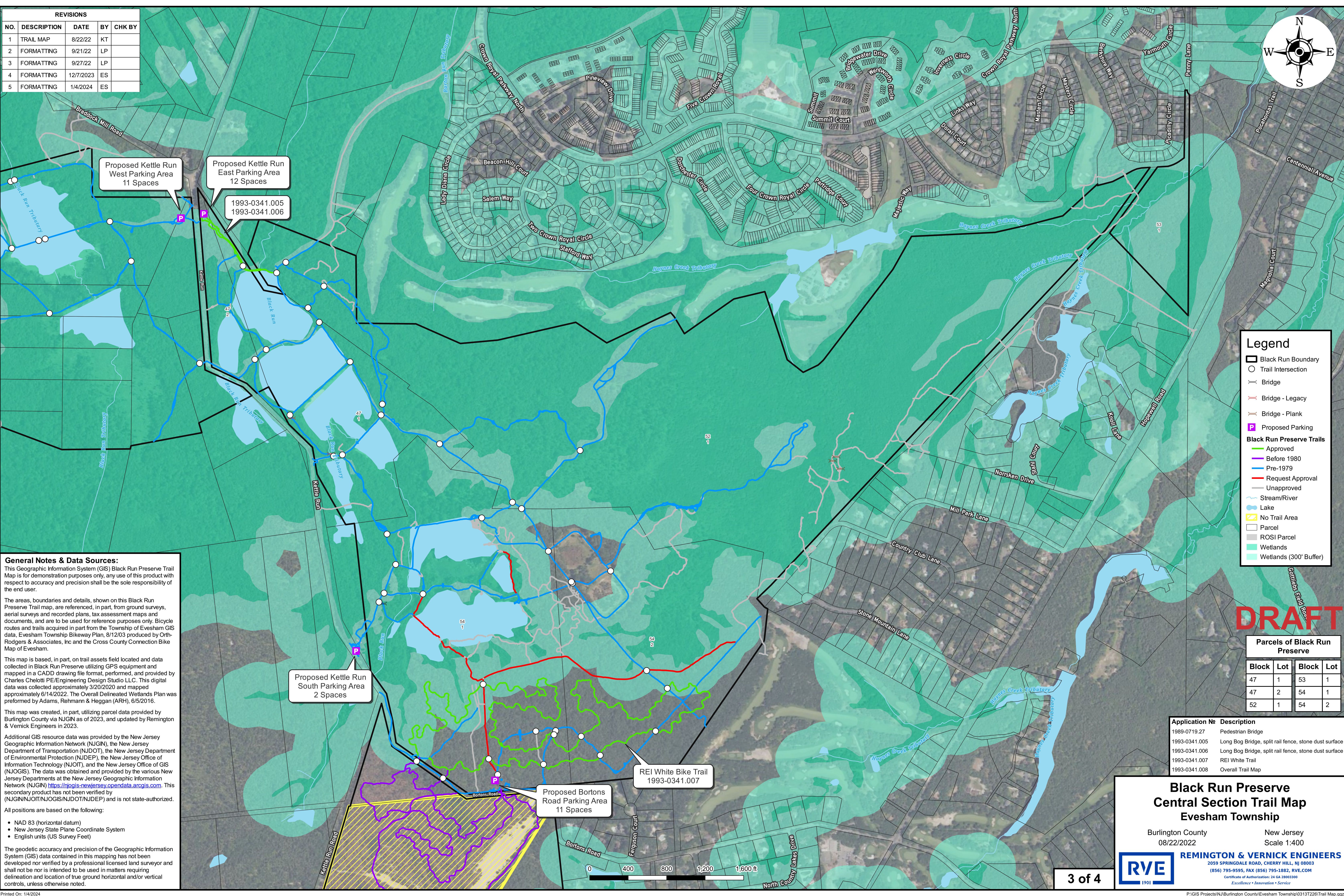
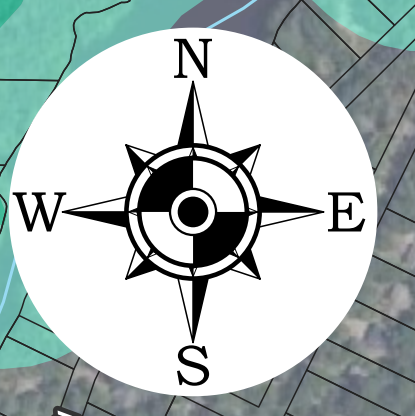

Legend

- Black Run Boundary
- Trail Intersection
- Bridge
- Bridge - Legacy
- Bridge - Plank
- Proposed Parking
- Black Run Preserve Trails**
 - Approved
 - Before 1980
 - Pre-1979
 - Request Approval
 - Unapproved
- Stream/River
- Lake
- No Trail Area
- Parcel
- ROSI Parcel
- Wetlands
- Wetlands (300' Buffer)

General Notes & Data Sources:
 This Geographic Information System (GIS) Black Run Preserve Trail Map is for demonstration purposes only, any use of this product with respect to accuracy and precision shall be the sole responsibility of the end user.

The areas, boundaries and details, shown on this Black Run Preserve Trail map, are referenced, in part, from ground surveys, aerial surveys and recorded plans, tax assessment maps and documents, and are to be used for reference purposes only. Bicycle routes and trails acquired in part from the Township of Evesham GIS data, Evesham Township Bikeway Plan, 8/12/03 produced by Orth-Rodgers & Associates, Inc and the Cross County Connection Bike Map of Evesham.

This map is based, in part, on trail assets field located and data collected in Black Run Preserve utilizing GPS equipment and mapped in a CADD drawing file format, performed, and provided by Charles Chelotti PE/Engineering Design Studio LLC. This digital data was collected approximately 3/20/2020 and mapped approximately 6/14/2022. The Overall Delineated Wetlands Plan was performed by Adams, Rehmann & Heggan (ARH), 6/5/2016.

This map was created, in part, utilizing parcel data provided by Burlington County via NJGIN as of 2023, and updated by Remington & Vernick Engineers in 2023.

Additional GIS resource data was provided by the New Jersey Geographic Information Network (NJGIN), the New Jersey Department of Transportation (NJDOT), the New Jersey Department of Environmental Protection (NJDEP), the New Jersey Office of Information Technology (NJGIT), and the New Jersey Office of GIS (NJOGIS). The data was obtained and provided by the various New Jersey Departments at the New Jersey Geographic Information Network (NJGIN) <https://njgis-newjersey.opendata.arcgis.com>. This secondary product has not been verified by (NJGIN/NJGIT/NJOGIS/NJDOT/NJDEP) and is not state-authorized.

All positions are based on the following:

- NAD 83 (horizontal datum)
- New Jersey State Plane Coordinate System
- English units (US Survey Feet)

The geodetic accuracy and precision of the Geographic Information System (GIS) data contained in this mapping has not been developed nor verified by a professional licensed land surveyor and shall not be nor is intended to be used in matters requiring delineation and location of true ground horizontal and/or vertical controls, unless otherwise noted.

DRAFT

Parcels of Black Run Preserve

Block	Lot	Block	Lot
47	1	53	1
47	2	54	1
52	1	54	2

Application #	Description
1989-0719.27	Pedestrian Bridge
1993-0341.005	Long Bog Bridge, split rail fence, stone dust surface
1993-0341.006	Long Bog Bridge, split rail fence, stone dust surface
1993-0341.007	REI White Trail
1993-0341.008	Overall Trail Map

Black Run Preserve Central Section Trail Map Evesham Township

Burlington County New Jersey
 08/22/2022 Scale 1:400

REMINGTON & VERNICK ENGINEERS
 2059 SPRINGDALE ROAD, CHERRY HILL, NJ 08003
 (856) 795-9595, FAX (856) 795-1882, RVE.COM
 Certificate of Authorization: 24 GA 28003300
 Excellence • Innovation • Service

RVE 1901



REVISIONS				
NO.	DESCRIPTION	DATE	BY	CHK BY
1	TRAIL MAP	8/22/22	KT	
2	FORMATTING	9/21/22	LP	
3	FORMATTING	9/27/22	LP	
4	FORMATTING	12/7/2023	ES	
5	FORMATTING	1/4/2024	ES	

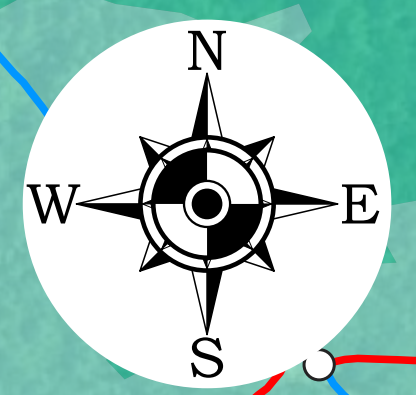

Proposed Kettle Run South Parking Area
2 Spaces

Proposed Bortons Road Parking Area
11 Spaces

REI White Bike Trail
1993-0341.007

Legend	
	Black Run Boundary
	Trail Intersection
	Bridge
	Bridge - Legacy
	Bridge - Plank
	Proposed Parking
Black Run Preserve Trails	
	Approved
	Before 1980
	Pre-1979
	Request Approval
	Unapproved
	Stream/River
	Lake
	No Trail Area
	Parcel
	ROSI Parcel
	Wetlands
	Wetlands (300' Buffer)

General Notes & Data Sources:
This Geographic Information System (GIS) Black Run Preserve Trail Map is for demonstration purposes only, any use of this product with respect to accuracy and precision shall be the sole responsibility of the end user.

The areas, boundaries and details, shown on this Black Run Preserve Trail map, are referenced, in part, from ground surveys, aerial surveys and recorded plans, tax assessment maps and documents, and are to be used for reference purposes only. Bicycle routes and trails acquired in part from the Township of Evesham GIS data, Evesham Township Bikeway Plan, 8/12/03 produced by Orth-Rodgers & Associates, Inc and the Cross County Connection Bike Map of Evesham.

This map is based, in part, on trail assets field located and data collected in Black Run Preserve utilizing GPS equipment and mapped in a CADD drawing file format, performed, and provided by Charles Chelotti PE/Engineering Design Studio LLC. This digital data was collected approximately 3/20/2020 and mapped approximately 6/14/2022. The Overall Delineated Wetlands Plan was performed by Adams, Rehmann & Heggan (ARH), 6/5/2016.

This map was created, in part, utilizing parcel data provided by Burlington County via NJGN as of 2023, and updated by Remington & Vernick Engineers in 2023.

Additional GIS resource data was provided by the New Jersey Geographic Information Network (NJGIN), the New Jersey Department of Transportation (NJDOT), the New Jersey Department of Environmental Protection (NJDEP), the New Jersey Office of Information Technology (NJOT), and the New Jersey Office of GIS (NJOGIS). The data was obtained and provided by the various New Jersey Departments at the New Jersey Geographic Information Network (NJGIN) <https://njgis-newjersey.opendata.arcgis.com>. This secondary product has not been verified by (NJGIN/NJOT/NJOGIS/NJDOT/NJDEP) and is not state-authorized.

All positions are based on the following:

- NAD 83 (horizontal datum)
- New Jersey State Plane Coordinate System
- English units (US Survey Feet)

The geodetic accuracy and precision of the Geographic Information System (GIS) data contained in this mapping has not been developed nor verified by a professional licensed land surveyor and shall not be nor is intended to be used in matters requiring delineation and location of true ground horizontal and/or vertical controls, unless otherwise noted.

DRAFT

Parcels of Black Run Preserve			
Block	Lot	Block	Lot
57	1	57	1.01

Application No	Description
1989-0719.27	Pedestrian Bridge
1993-0341.005	Long Bog Bridge, split rail fence, stone dust surface
1993-0341.006	Long Bog Bridge, split rail fence, stone dust surface
1993-0341.007	REI White Trail
1993-0341.008	Overall Trail Map

**Black Run Preserve
Southern Section (Aerohaven)
Trail Map**

Evesham Township

Burlington County New Jersey
08/22/2022 Scale 1:200

REMINGTON & VERNICK ENGINEERS
2059 SPRINGDALE ROAD, CHERRY HILL, NJ 08003
(856) 795-9595, FAX (856) 795-1882, RVE.COM
Certificate of Authorization: 24 GA 28003300
Excellence • Innovation • Service





Township of Evesham "Respecting Diversity, Preserving Dignity"

Mayor Jaclyn Veasy - Councilwoman Heather Cooper - Councilwoman Ginamarie Espinoza - Councilman Eddie Freeman, III - Councilwoman Patricia Hansen

984 Tuckerton Road • Marlton • NJ 08053 • 856-983-2900 • www.evesham-nj.org

3. Proposed MOA Summary:

In effort to address the overall permitting status of the 700+ acre park, the Township proposes to keep moving forward to document all the trails, parking areas, and items within the park to the Township is seeking permission to remain (kiosk signage and benches). As evidenced by historic aerial imagery most of the trails have existed in the BRP since pre 1979. Additionally, the request includes an existing trail (shown in red on the overall map for the southern section) for permission to remain.

The request includes consideration for direction to continue moving forward with a MOA project that will include approval of the following:

- 1) Western Section: Change in existing trail material surface from earthen to crushed gravel (as was approved for Pemberton Lakes Trail). 4,640 linear feet @ a width of 5 feet, the proposed disturbance is 23,200 square feet, or 0.53 acres. The proposed trail improvements would make the existing trail firm, stable and flat from side to side so it is more accessible to individuals with mobility issues.
- 2) Western Section: Installation of one pedestrian ADA compliant bridge to reconnect two existing trails (that are proposed to be include ADA upgrades).



Township of Evesham "Respecting Diversity, Preserving Dignity"

Mayor Jaclyn Veasy - Councilwoman Heather Cooper - Councilwoman Ginamarie Espinoza - Councilman Eddie Freeman, III - Councilwoman Patricia Hansen

984 Tuckerton Road • Marlton • NJ 08053 • 856-983-2900 • www.evesham-nj.org

- 3) To permit existing park amenities to remain including board walks, kiosk signage at parking area, park signage, and benches. To allow additional newly proposed park amenities including park signage and benches as appropriate.
 - 4) To permit 5 existing parking areas to remain and to include changes in surface material to allow the installation of ADA compliant parking spaces.
 - 5) To permit the existing trail shown in red (southern section) to remain.
4. Partners involved in this effort to address permitting within the BRP:
- i. Evesham Township
 - ii. Friends of Black Run Preserve
 - iii. Pinelands Preservation Alliance

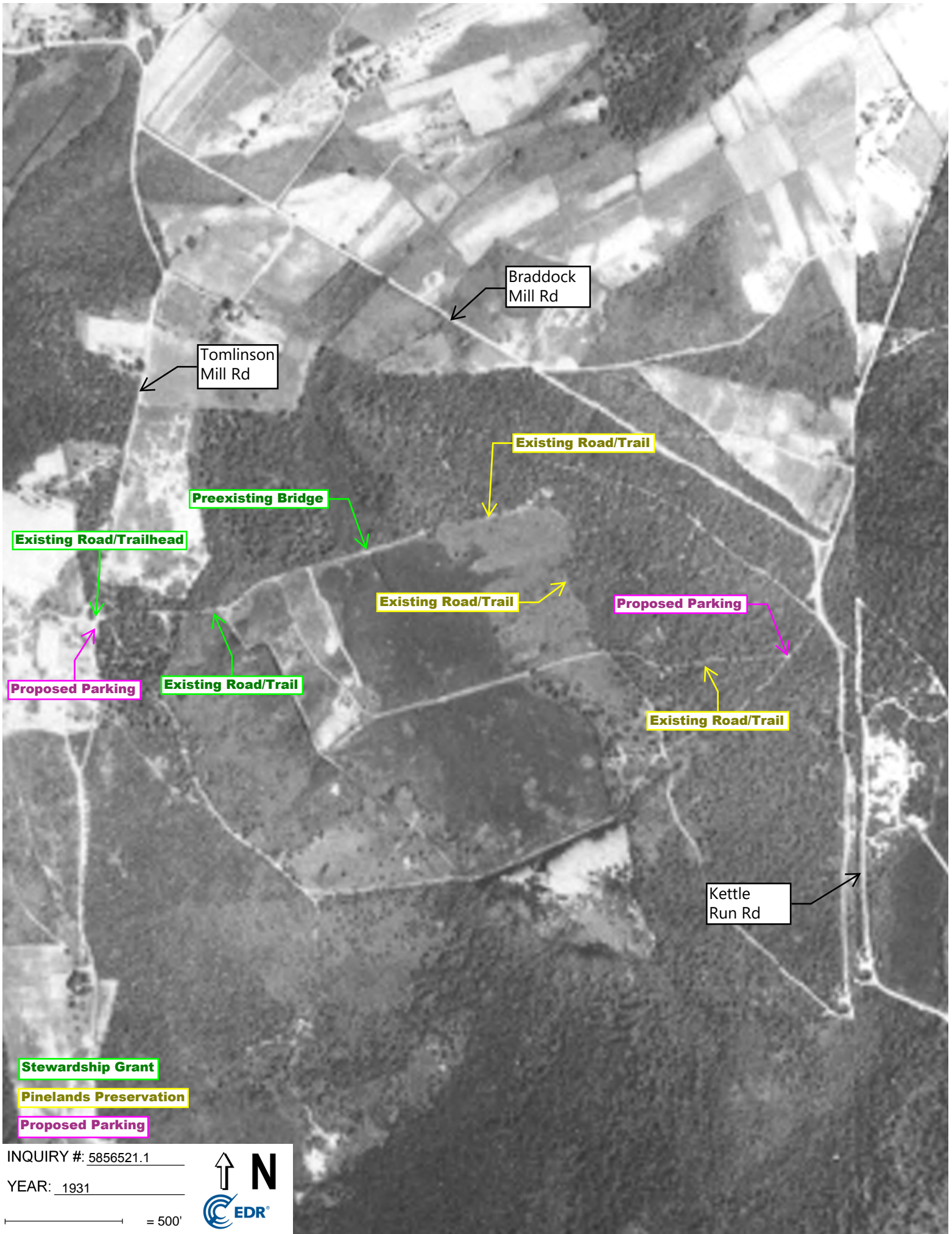

Braddock Mill Rd

Tomlinson Mill Rd

Existing Road/Trail

Preexisting Bridge

Existing Road/Trailhead

Existing Road/Trail

Proposed Parking

Proposed Parking

Existing Road/Trail

Existing Road/Trail

Kettle Run Rd

Stewardship Grant

Pinelands Preservation

Proposed Parking

INQUIRY #: 5856521.1

YEAR: 1931

Scale bar: = 500'



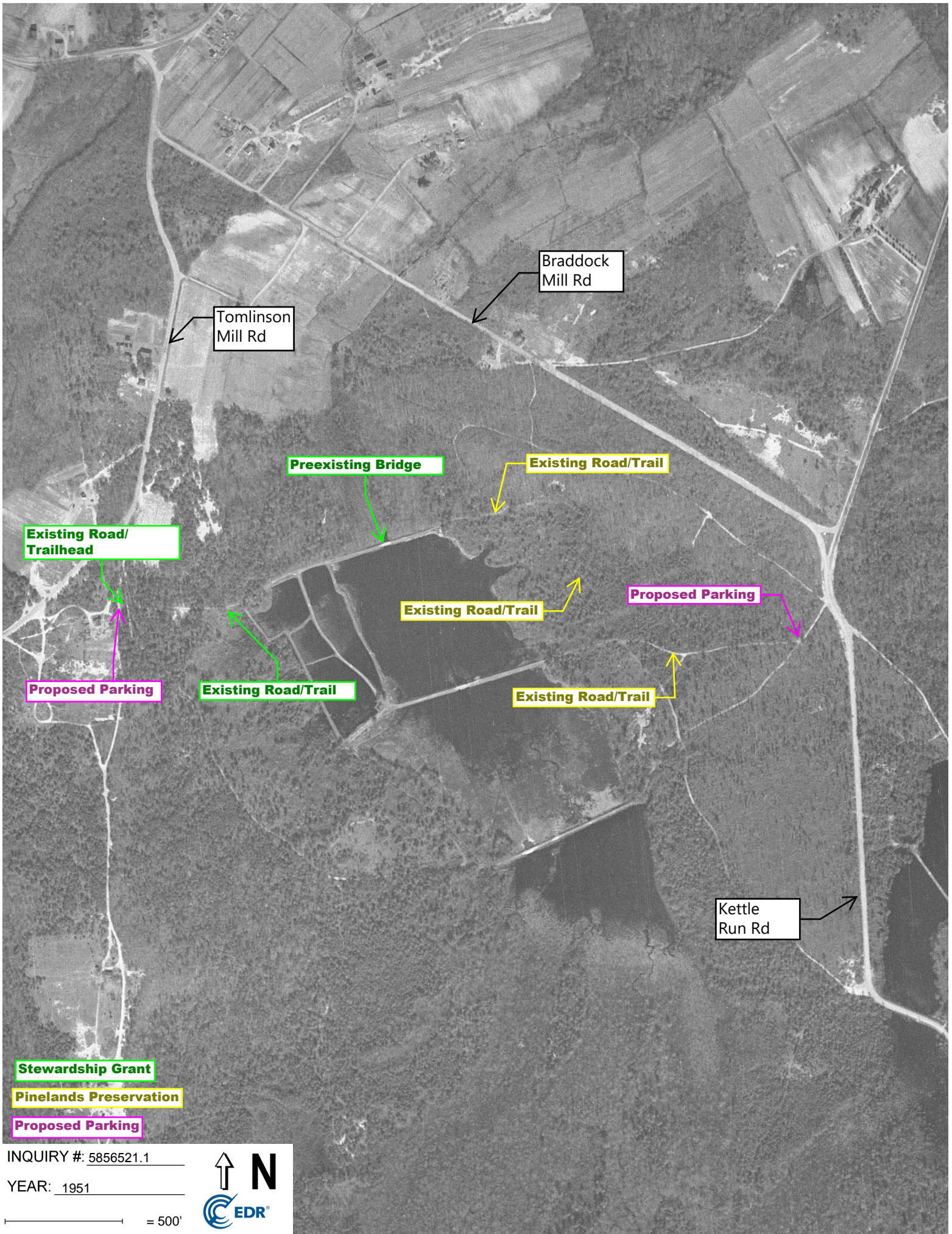

Braddock Mill Rd

Tomlinson Mill Rd

Preexisting Bridge

Existing Road/Trail

Existing Road/Trailhead

Existing Road/Trail

Proposed Parking

Proposed Parking

Existing Road/Trail

Existing Road/Trail

Kettle Run Rd

Stewardship Grant

Pinelands Preservation

Proposed Parking

INQUIRY #: 5856521.1

YEAR: 1951

500'



No.	REVISION	DATE	BY	CHK

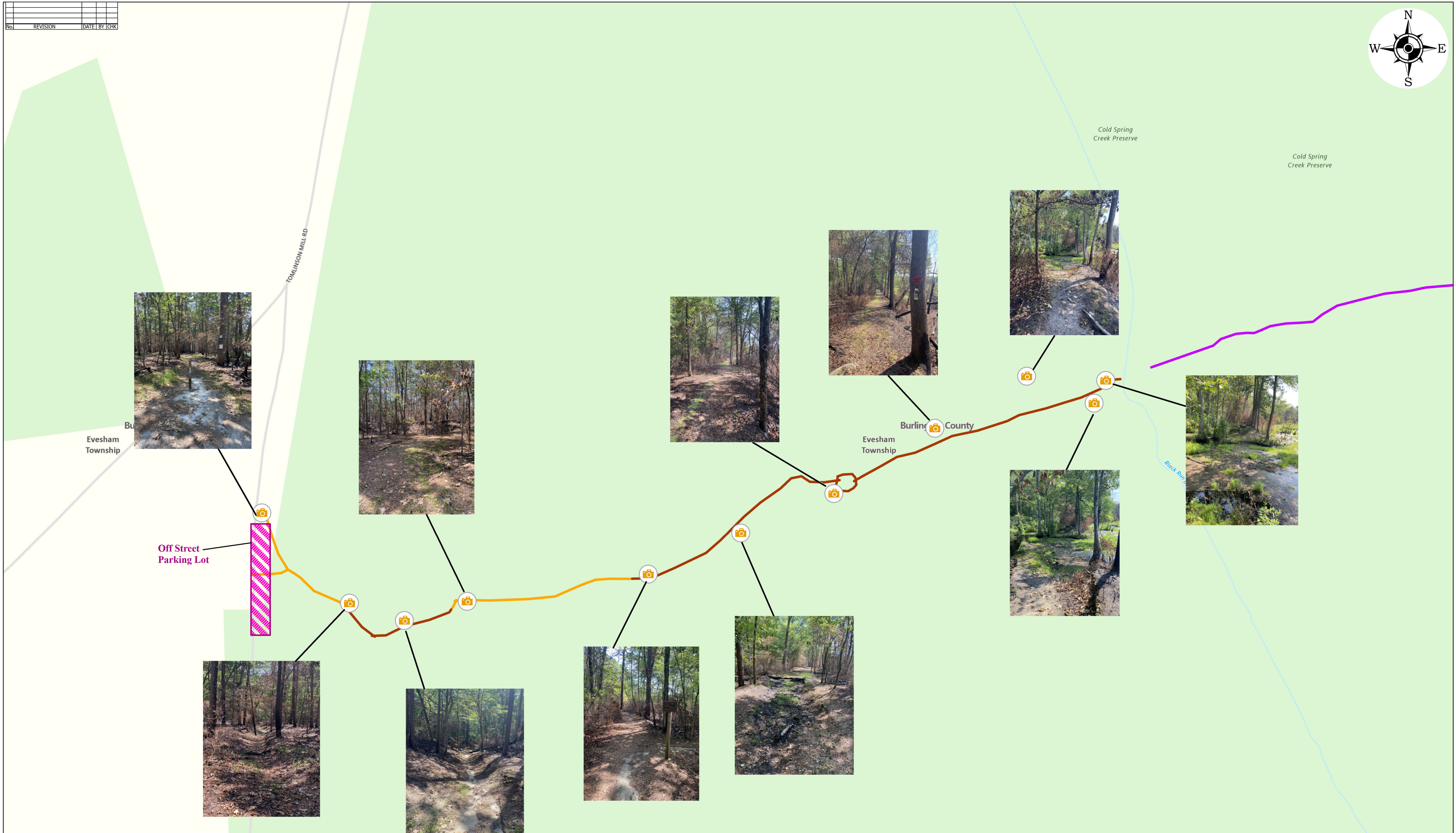

Source: Esri, DeLorme, Garmin, etc.
 This Geographic Information System (GIS) Black Run Preserve Trail Improvement map is for informational purposes only. No warranty is made by the provider with respect to accuracy and precision. The user assumes all responsibility for any use of this information.
 The areas, boundaries and details shown on this Black Run Preserve Trail Improvement map are intended to be used for general reference only. They are not intended to be used for legal purposes. The user assumes all responsibility for any use of this information.
 Additional field photos and images were provided by the New Jersey Geographic Information Network (NJGIN). Data was obtained and provided by the New Jersey Geographic Information Network (NJGIN) (http://njgin.state.nj.us/).
 Additional satellite imagery, including data, such as, waterways, boundaries, infrastructure, and other information, was obtained from the New Jersey Department of Environmental Protection (NJDEP). The user assumes all responsibility for any use of this information.
 All numbers are based on the following:
 NAD 83 (Datum of 1983)
 State Plane State Plane Coordinate System (SPCS) projection based on spatial location of English units (ft)
 The provider assumes no liability for the Geographic Information System (GIS) data contained in this report. The user assumes all responsibility for any use of this information. The user assumes all responsibility for any use of this information. The user assumes all responsibility for any use of this information.

Legend

- TRAIL/ROAD
- TRAIL Existing
- ADJACENT TRAIL
- Field Photos

**BLACK RUN PRESERVE
TRAIL IMPROVEMENT**

EVESHAM TOWNSHIP

BURLINGTON COUNTY NJ
07/19/2023 SCALE: 1" = 150'

REMINGTON & VERNICK ENGINEERS
2059 SPRINGDALE ROAD, CHERRY HILL, NJ 08003
(856) 795-9595, FAX (856) 795-1882, RVE.COM
Certificate of Accreditation: 24-02-200003390
Excellence • Innovation • Service

DRAFT

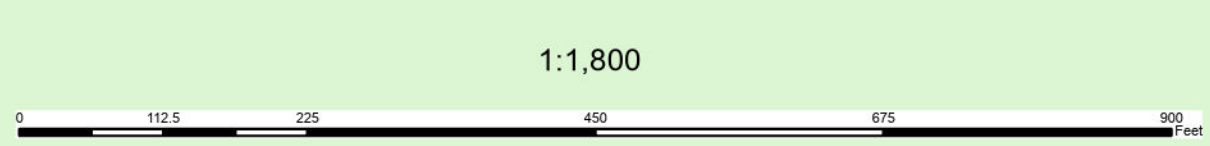

Black Run Preserve Accessibility Trail Enhancement



PINELANDS
PRESERVATION
ALLIANCE



Proposal by Pinelands Preservation Alliance and Evesham Twp.

The importance of this project

1. Create an inclusive low-impact recreation site for the community.
2. Promote community health and wellness.
3. Provide a safe space for gathering and activity for everyone.
4. Encourage low-impact activity for all members of the community.
5. Provide inclusive access to conserved wild areas with great scenic views.
7. Help all residents connect with Evesham's natural places.
8. Improve overall value of the preserve for the community.

Scouting the Site



Scouting the Site



Scouting the Site



Why do the work: Health, Recreation, Education, Community Connection



Why do the work: Health, Recreation, Education, Community Connection



Why do the work: Health, Recreation, Education, Community Connection



Examples of Similar Work: County Park Level



Boundary Creek – Burlington County Parks

Examples of Similar Work: County Park Level



Eno's Pond – Ocean County Parks

Examples of Similar Work: State Park Level



Wharton State Forest, Batsto Village –
Red Trail



Atsion Recreation Area – Red/Blue
Trail

Examples of Similar Work: State Park Level



Brendan T. Byrne State Forest – Cranberry Trail



Township of Evesham

"Respecting Diversity, Preserving Dignity"

Mayor Jaclyn Veasy - Councilwoman Heather Cooper - Councilwoman Ginamarie Espinoza - Councilman Eddie Freeman, III - Councilwoman Patricia Hansen

984 Tuckerton Road • Marlton • NJ 08053 • 856-983-2900 • www.evesham-nj.org

5. Offset Approximate Work Area = 8+ Acres. Restoration of former MUA basins.

